



European Road Transport Research Advisory Council

ERTRAC Strategic Research Agenda 2010

Towards a 50% more efficient road transport system by 2030

EXECUTIVE SUMMARY



For public consultation
May 2010

ERTRAC—The European Road Transport Research Advisory Council

ERTRAC, the European Road Transport Research Advisory Council, represents the diverse range of road transport stakeholders and brings them together with representatives from public authorities at the European, national, regional and urban levels.

The multi-stakeholder nature of ERTRAC makes it unique in being able to present an holistic and integrated view of road transport issues. ERTRAC's mission is to seize the opportunity for better coordination of private and public research activities, and to make specific recommendations for their implementation. ERTRAC delivers roadmaps for cross-cutting research that provide a reference for the future planning of European and national transport programmes. In addition, it is hoped that this reference provides an overarching framework for

research, innovation and technological development, as well as guidance for individual research planning.

Recent ERTRAC publications include *ERTRAC Road Transport Scenario 2030+ Road to Implementation*, and *European Roadmap: Electrification of Road Transport* (in cooperation with EPOSS and SmartGrids), two key reports on future road transport options. These documents, published in late 2009, represent the basis for the development of the new 2010 Strategic Research Agenda (SRA), which updates the previous ERTRAC SRA published in 2004. The aim of the SRA 2010 is to provide private and public decision makers with a set of up-to-date recommendations for strategic research and innovation priorities that recognize Europe's priorities for sustainable transport and environmental protection.

All major stakeholders and public bodies are represented in ERTRAC

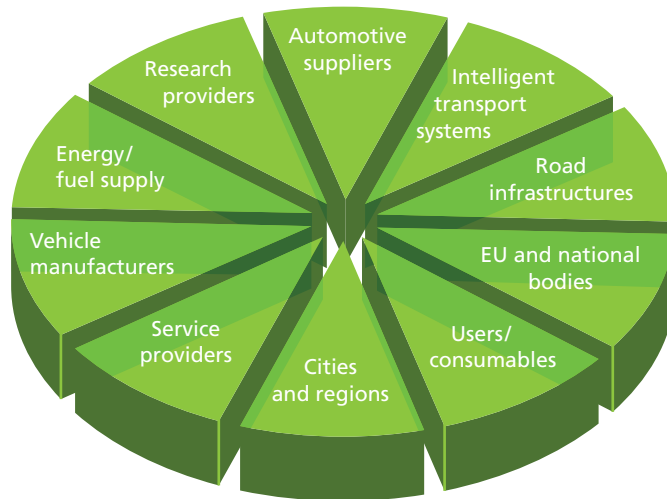

This Executive Summary is a draft document summarizing the full technical report which will be ready for publication in the summer of 2010. Its purpose is to encourage comments and input from private and public actors involved in transport research, with a view to further improving the framework for road transport development towards 2030. The full technical document may be downloaded from the ERTRAC website at www.ertrac.org.

Comments on this draft should be addressed to info@ertrac.org.

Letter from the ERTRAC Chair

Dear Reader,

ERTRAC is bringing together the stakeholders in the road transport system to develop a common Agenda for the research and innovation priorities needed to tackle the challenge of sustainable transport. This Agenda presents considerable challenges for European industry, and involves meeting a range of societal needs, including the decarbonization of road transport—a focal point in the current debate on global climate change—and energy security. Meeting these challenges will require significant change at the industrial level.

ERTRAC's initiative to revise its first Strategic Research Agenda follows up on the Lund Declaration of 2009, which empowered the European Technology Platforms to address the 'grand challenges of our time' through issue-driven research and innovation. The revised Agenda provides decision makers with clear, integrated research and innovation priorities that are based on a consistent systems approach, and includes recommendations for future implementation.

The guiding objective of the SRA is to deliver, by 2030, a road transport system that is 50% more efficient than today. This objective addresses the societal demand for decarbonization, reliability and safety of the road transport system, as well as the growth, employment, skills and resource issues that are of critical importance for a globally competitive European road transport industry. Indeed, meeting the evolving demand for new sustainable and affordable mobility solutions will require a major transition towards a wide range of complementary, energy-efficient vehicle designs and powertrains. These new technologies will enable the introduction of a variety of (renewable) energy sources to the transport system and, through the use of information and communication technology (ICT), will become highly integrated with the next generation of road infrastructure and services.

These opportunities will, however, present the automotive manufacturing and energy industries with the challenge of being able to adapt to these new market demands at a pace which is fast enough to meet society's needs, whilst at the same time ensuring an adequate return on investment. Such a complex balancing process will require committed discussion within public-private partnerships, for example, in the context of the EU's 'Europe 2020 Strategy' for sustainable growth and jobs. This strategy aims, amongst other things, to deliver high quality employment through a 'resource-efficient Europe', in particular by improving fuel consumption and diversifying energy through the use of renewable fuels.

It is important to understand that the objective of achieving a sustainable road transport system will be realized only through coordinated action by all relevant stakeholders to ensure that the necessary technological advances take place in all components of the system. Thanks to its multi-stakeholder nature, ERTRAC is well placed to make recommendations to European and national decision makers on such coordinated action, and this is reflected by the priorities in the Strategic Research Agenda.

As ERTRAC moves forward in its efforts to implement this integrated SRA, it remains committed to an ongoing dialogue with all the stakeholders. ERTRAC invites comments and recommendations on the revised SRA from all parties, and encourages both private and public research actors to work in partnership, dedicated to a sustainable and competitive Europe.



Helmut List

AVL List GmBH—Chairman and CEO



Wolfgang Steiger

Volkswagen—Director of Future Technologies



Jean-Luc di Paola-Galloni

Valeo—CEO's Delegate



Julio Garcia Ramon

POLIS—President



Zisis Samaras

LAT Thessaloniki University—Director



Hans Ingvarsson

Swedish Transport Administration—Research Director

Towards a 50% more efficient road transport system by 2030: ERTRAC's Strategic Research Agenda

A European road transport system that is 50% more efficient than today could be achieved, by 2030, by adopting the range of research and innovation priorities defined in this Strategic Research Agenda.

This ambitious objective reflects ERTRAC's contribution to Europe's efforts to address the 'grand challenges of our time', and to bring sustainability to the European community (Lund, 2009). This contribution involves bringing significant improvements to the European road transport system. The research and innovation proposed in this SRA will enable such improvements by addressing the broad range of challenges related to the road transport system, including: the supply of energy and resources; global climate change and the environment; health and safety; and increased global competitiveness of the road transport industry leading to economic growth and high quality employment in Europe.

The approach taken by the SRA recognizes, in particular, the societal demand for decarbonization, reliability and safety of the road transport system from a user's perspective, and establishes clear guiding objectives towards 2030 for each of the related indicators (see Table 1).

In addition to the end-user's need for a more efficient road transport system, it also recognizes the urgent need to ensure global competitiveness of the road transport-related industry in general, and the automotive industry in particular. Aside from its domestic importance to the European economy and society, the European automotive industry is one of the most 'globalized' production sectors, and faces significant competition on the global market.

With regard to the **societal need for decarbonization in road transport**, the SRA focuses both on increasing the energy efficiency of road transport activities and on decarbonizing the energy they consume. This approach will make a considerable contribution towards the requirements of European policy on energy and climate change.

To address the **societal need for reliability of the road transport system**, the SRA focuses on improving the reliability of transport schedules and urban accessibility. Both of these indicators are strongly linked to economic growth and employment, and aim at reducing congestion and the significant related societal costs. Recognizing the extent to which today's society depends on mobility, the guiding objectives for 2030 imply a significant improvement in mobility that will not only benefit Europe's competitiveness in the global market, but also aims to enhance societal integration throughout Europe, e.g. by making the peripheral regions more accessible and allowing much greater occupational mobility.

With regard to the **societal need for safety and security in road transport**, the focus of the SRA is on reducing fatalities and severe injuries, as well as reducing the amount of freight cargo lost due to theft and damage. The policy of reducing fatalities is a long-standing objective which reflects the ongoing efforts of the European Commission, the Member States and industry in reducing fatalities on the roads. However, ERTRAC has extended the reach of this indicator so that it now also includes the reduction of severe injuries. The indicator on cargo lost to theft and damage calls for

Table 1 Guiding objectives for 2030

	Indicator	Guiding objective
Decarbonization	Energy efficiency: urban passenger transport	+80% *
	Energy efficiency: long-distance freight transport	+40% *
	Renewables in the energy pool	Biofuels: 25% Electricity: 5%
Reliability	Reliability of transport schedules	+50% *
	Urban accessibility	Preserve Improve where possible
Safety	Fatalities and severe injuries	-60% *
	Cargo lost to theft and damage	-70% *

* Versus 2010 baseline

Figure 1 The need for a sustainable road transport system will shape the development of future vehicle concepts

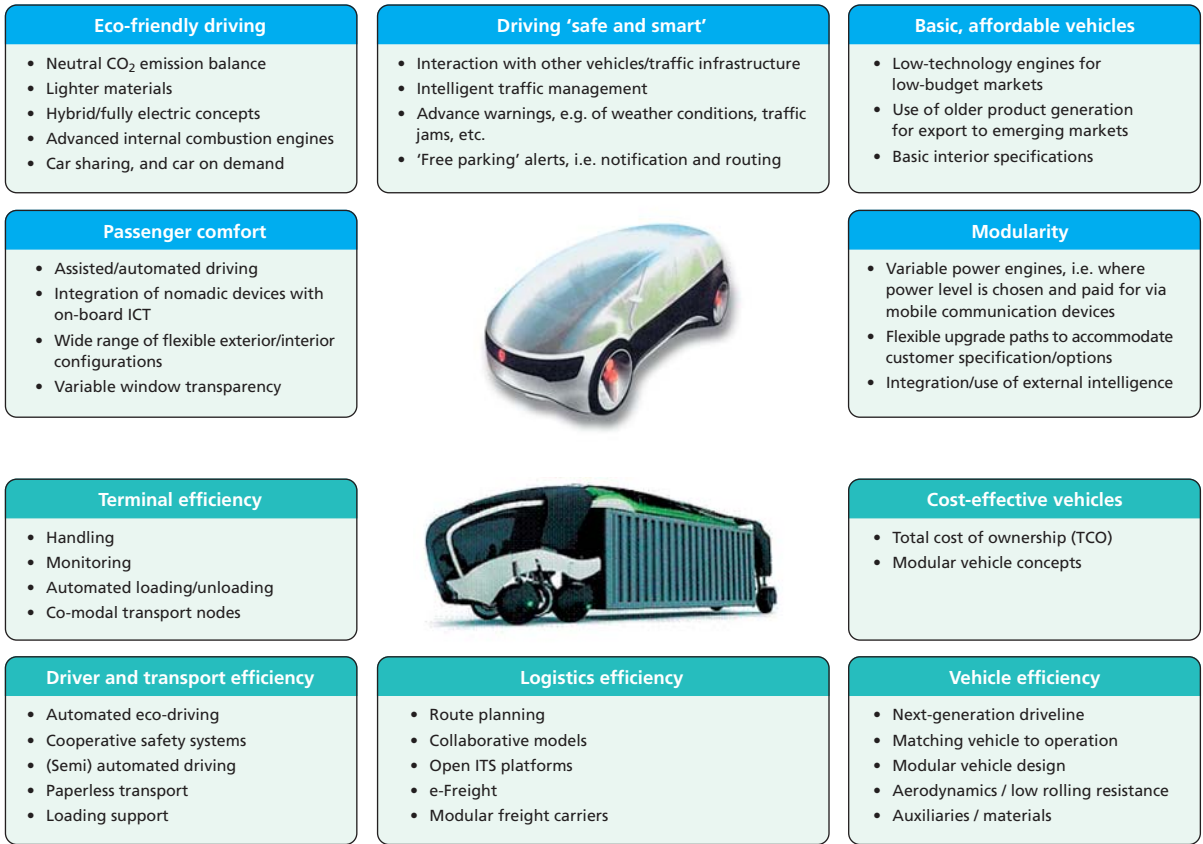

action on international trade, where security is a clear priority. A lack of security has a negative impact on trade and, hence, also on competitiveness; improving cargo security will therefore enhance the notion of free trade. Efforts to protect against theft would focus particularly on the entry points into Europe, and would involve enhancing EU policies concerned with the development of neighbouring regions.

Finally, efforts to address the urgent societal need for global competitiveness of the automotive industry aim at producing vehicles that are affordable and which meet (domestic and global) consumer's demands (see Figure 1), as well as producing them in a sustainable way. The indicators selected to measure the required changes in the production systems are: total cost of ownership (TCO); earnings before interest and taxes (EBIT); energy footprint of the supply chain; and the human development index (HDI).

To achieve these ambitious guiding objectives for 2030 will require a comprehensive and consistent 'systems approach'. Two such approaches are

presented in this SRA, one involving the road transport system as it is used and experienced by the consumer, end-user and citizen (see Figure 2 and page 6), and the second involving the global competitiveness of the European automotive industry's production system (see page 9).

Figure 2 A systems approach to achieving a 50% more efficient road transport system

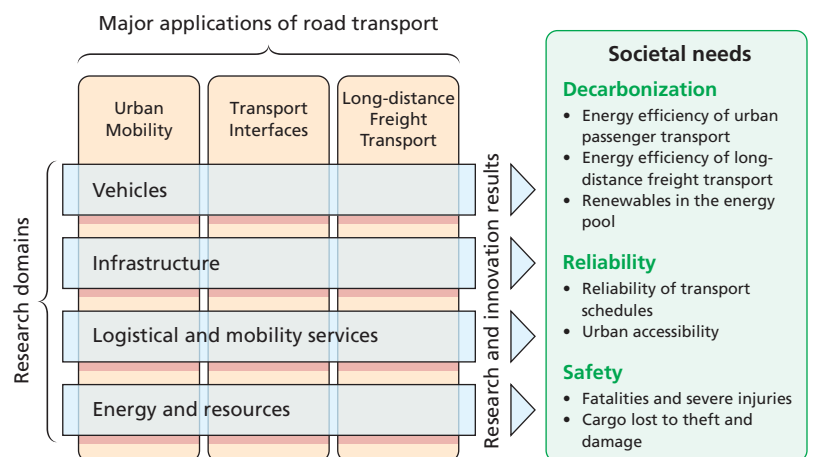

The systems approach for road transport applications

The systems approach to address the major functions of the road transport system focuses on the following three major applications:

1. urban mobility;
2. long-distance freight transport; and
3. transport interfaces.

The transport interfaces will provide a seamless link between modes and networks, and between urban mobility and long-distance freight transport systems. Together, these applications will provide a transport system that serves the road transport demand of more than 80% of the population (ERTRAC, 2009a), hence they are of the greatest economic significance.

Although this SRA places a focus on the three major road transport applications mentioned above, ERTRAC acknowledges the importance of the social interaction between urban and rural territories. Wherever possible, the guidelines contained in this research portfolio should also consider rural scenarios, in particular with regard to energy and safety.

As a part of the process of identifying and prioritizing the areas of research and innovation for discussion in this SRA, ERTRAC has drawn on its

vision for 2030 and the decades beyond (ERTRAC, 2009a). The key points outlined in ERTRAC’s vision document are encompassed in each of the four enabling research domains indicated in Figure 2 (i.e. for vehicles, infrastructure, logistical and mobility services, and energy and resources). These are described below.

Vehicles

In the decades leading to 2050, the challenge will be the need for a wide range of complementary propulsion systems and fuel/energy types to be developed simultaneously (see Figure 3). Although the electrification of road transport will be a strong and inevitable trend (for which ERTRAC, in alliance with EPoSS and SmartGrids, has established a clear roadmap) the fact is that, by 2030, the internal combustion engine (ICE) will remain the dominant propulsion technology.

Advances in vehicle technology will see the progressive introduction of ICT. This will not only bring advances in vehicle performance and driver support systems, but will also enable the exchange of information with intelligent infrastructure and a variety of system services. For example, in the case of

Figure 3 The evolution of passenger road transport energy source and propulsion technology, towards 2050

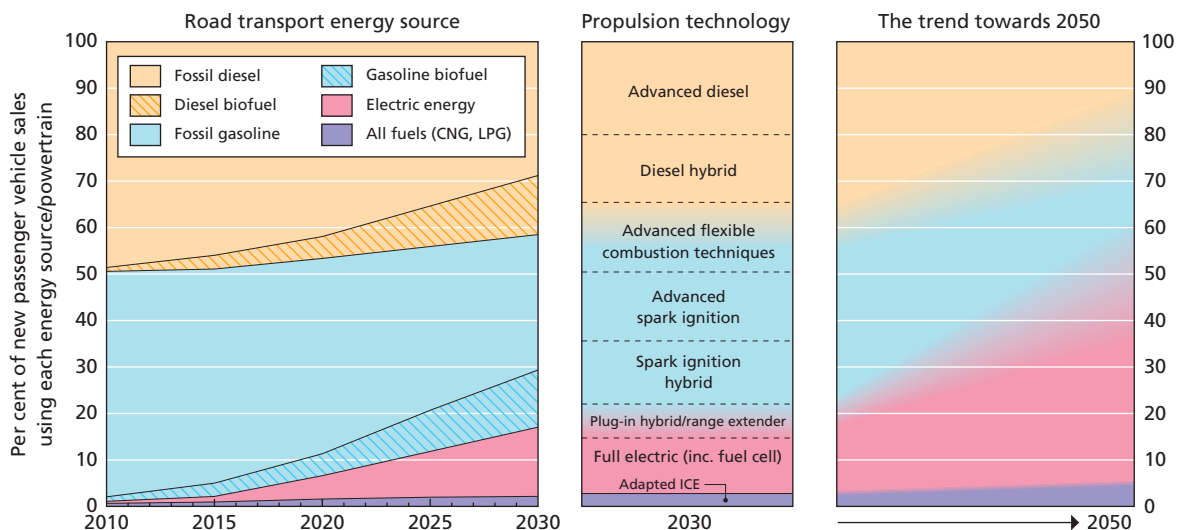

the electrification of road transport, this would include communications with other sectors, such as electricity generation and distribution.

A further trend will be the increasing variety of vehicle concepts that are able to adapt to the diversifying mobility demands of passengers and the freight transport sector. This trend will be further encouraged through urban development and environmental policies (e.g. on noise abatement).

The cost-effective development of such a wide array of energy sources and associated propulsion technologies and vehicle concepts will depend on economies of scale. In this respect, the forthcoming decades will see a strong trend towards extended standardization in terms of weight, dimensions and modularization.

Infrastructure

The rate of expansion of the road transport infrastructure will not keep pace with the increase in demand for road transport services. The critical challenge will therefore be to accommodate the growing transport demand (an estimated 50% increase over the coming two decades) through measures that increase its intrinsic capacity (e.g. the number of vehicles and travellers per area, and

infrastructure uptime) as well as through advanced demand management measures. The trend will be towards the swift development and deployment of next-generation infrastructure technology, and network management concepts, procedures and practices, to ensure that traffic density and infrastructural uptime remain at optimal levels, and that the road network is adaptable, automated and resilient.

As in-vehicle ICT systems are introduced, together with ICT-based logistics and mobility services, ICT-driven intelligence will also be progressively introduced into the road infrastructure.

The use of 'multi-modal hubs' (i.e. transport interfaces) and dedicated road capacity will enable the optimal integration of transport modes and services to relieve bottlenecks in specific areas of high congestion.

Logistics and mobility services

Increasing levels of congestion will place mounting pressure on the mobility services, particularly in the larger urban areas. This will give rise to comprehensive, integrated service concepts and business models that complement existing modes, and for which the dominant factor will be extensive cooperation

Figure 4 Energy sourcing in 2030 will involve a wider range of sources, carriers and powertrains

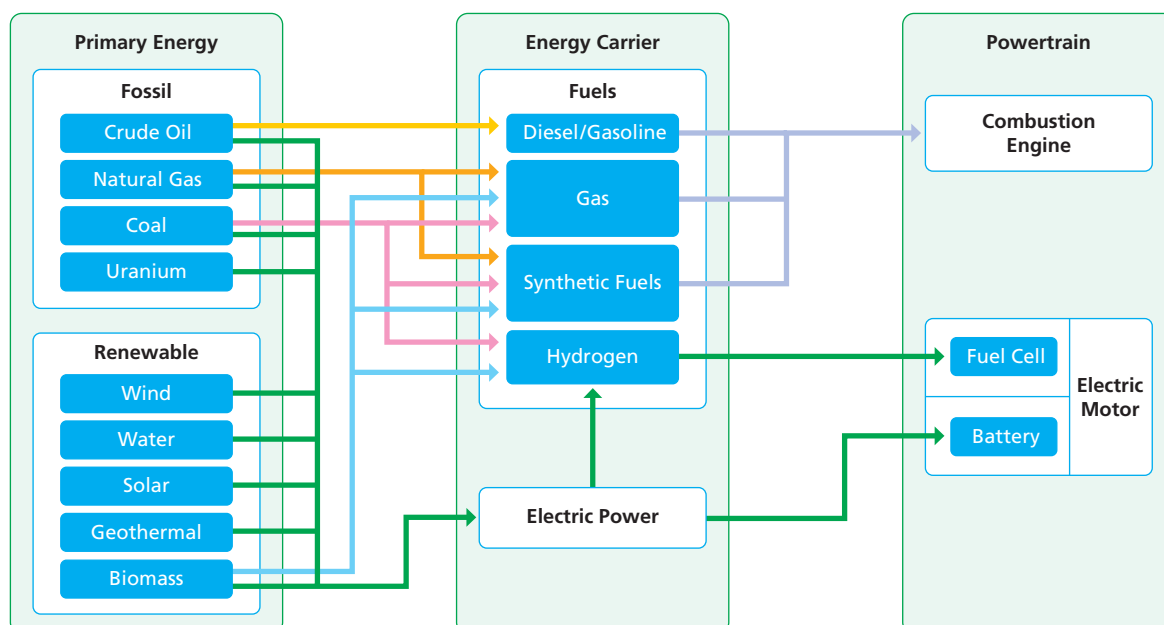

The systems approach for road transport applications ▶▶▶

between the various actors in the chain. In turn, this will serve to optimize the movement of goods and people to better reflect the actual demand for mobility services (including public transport). Models and service solutions will be introduced to support innovative business practices, route planning regimes and efficient trans-shipment of goods (in particular, over the 'last mile') and people, between modes and networks. Again, ICT and a better knowledge of transport demand will play a major role in these developments, as will the trend towards extended standardization for freight carriers in terms of dimensions and modularization.

Energy and resources

Although the energy basis for road transport will diversify considerably over the coming decades, the expectation is that fossil-based fuels will still dominate the energy pool for road transport in 2030. However, the supply of crudes and distillates will not be able to keep pace with the increase in global demand, and hence, the future energy market will become volatile

and competitive. Efforts will therefore aim at taking a 'greening' approach to diversifying the fuel pool through the development of new combustion-based propulsion technologies (see Figure 4) in order to achieve optimal performance on a well-to-wheels basis.

Additional decarbonization will occur through the increased uptake of electrically powered drivetrains, for which the electricity supplied by the power sector would need to be generated from renewable energy sources. However, the challenge will be how to store the electricity onboard the vehicle in such way that it can compete with hydrocarbon fuels in terms of the required energy density (see Figure 5). In addition, the minerals used in the production of electric vehicles (e.g. neodymium, dysprosium and copper) are scarce and unevenly distributed throughout the world. Hence, to rely on such minerals would limit the security of supply and lead to fluctuations in pricing. There is, therefore, a strong drive towards minimizing the use of, and recycling, such precious materials and, potentially, replacing them with more abundant alternatives.

Figure 5 Mobility solutions for both urban and long-distance travel

In urban areas, where travel distances are well below 200 km, battery-electric propulsion is a feasible option for motorized transport. Longer distances will require the use of other powertrains including ICE. In the context of the European road transport system over the next decades, the development of complementary solutions will be key to meeting mobility demands.

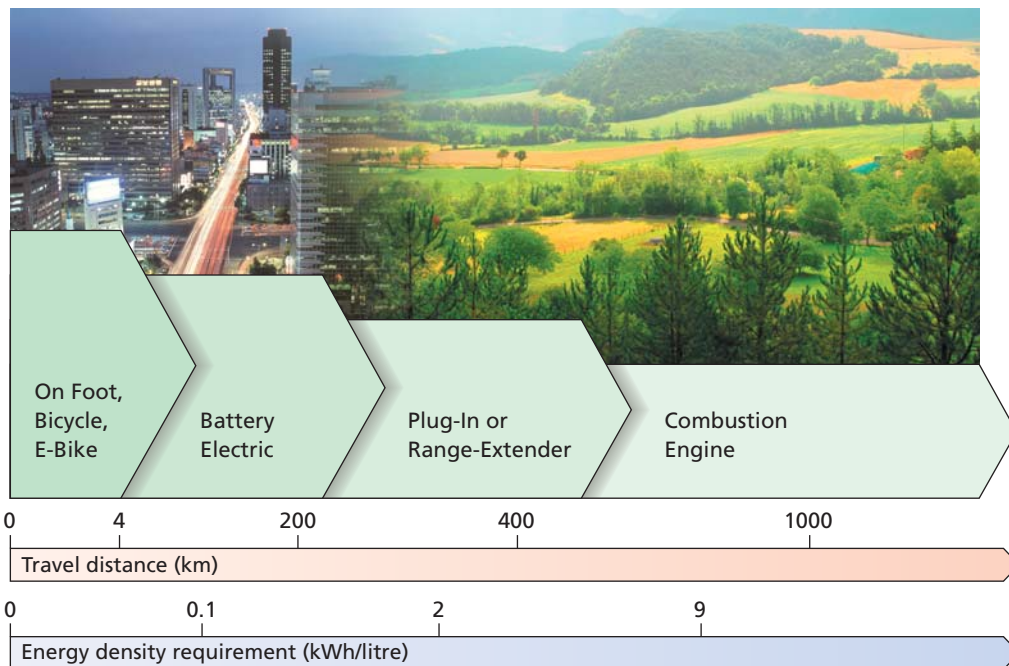

The systems approach for global competitiveness

Achieving the economic, environmental and social aspirations for Europe’s future will require European industry to remain successful in the global marketplace (see Figure 6). Currently, Europe is at the leading edge of the development of energy-efficient ICEs. The strategy proposed for the European motor industry is based on a two-fold approach which involves:

- improving the efficiency of conventional engines; and
- making electrically-powered mobility a reality for the European consumer.

During the next decades, the global market balance for the automotive industry will shift significantly in favour of the currently emerging markets in the BRIC nations (Brazil, Russia, India, China), as the rate of motorization in these countries begins to outpace that in Europe. The capacity for innovation in these countries will also grow as they benefit from their increasing share of the global mass markets, and this will place Europe in a critical position as it struggles to maintain its competitiveness. Furthermore, the ICE—originally developed to meet the high levels of

demand for mobility—will become less popular due to the increasing demand for *clean mobility* which, in turn, will lead to the emergence of the electric vehicle concept. The European automotive industry will need to adapt to this transition in technology and markets on a global scale by investing in new production systems designed to achieve the two top-level objectives of:

- a) meeting society’s needs for a sustainable transport system; and
- b) maintaining Europe’s leading position in the global marketplace.

The industry will face significant levels of competition in two important areas. In the research and innovation arena, there will be competition over the available levels of skill and funding required to support the development of future technologies. By 2030, skill levels in the emerging markets will have matured and the high population of skilled workers will enable the industry in those countries to maintain a strong advantage. Competition will also exist in

Figure 6 The importance of social, environmental and economic factors in sustainable production systems

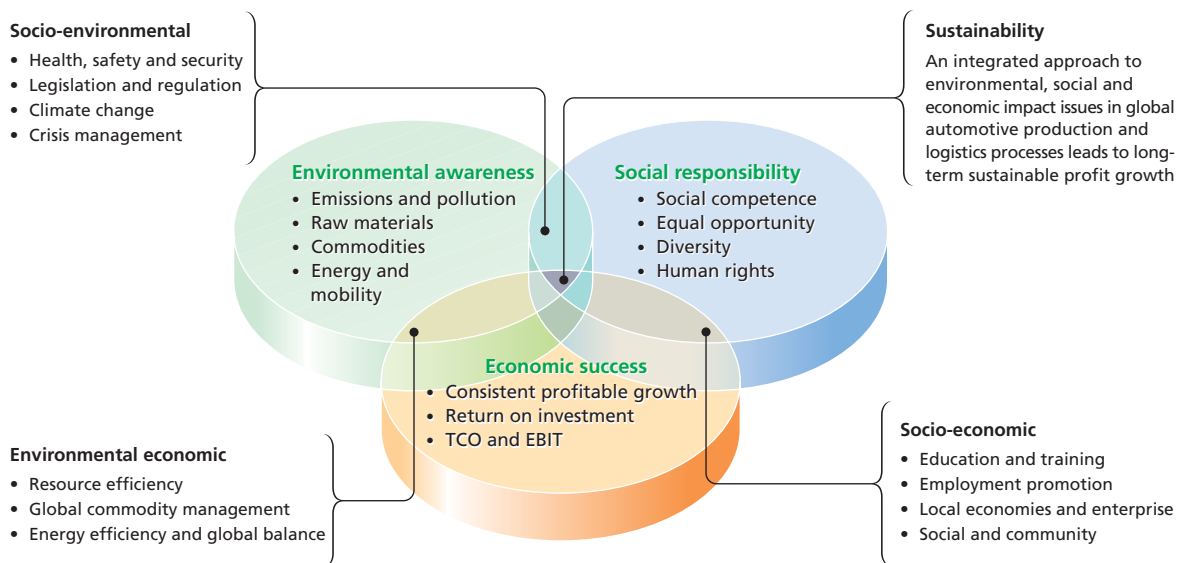

To enable the European automotive industry to maintain and strengthen its position in the global market, automotive production systems will need to become more efficient. This will involve improving on the range of management and organizational indicators shown in the Figure, with environmental awareness, social responsibility and economic success being key to maximizing sustainability.

The systems approach for global competitiveness ▶▶▶

relation to the emerging technologies and products themselves, as manufacturers aim to produce the most affordable or reliable products, or compete to protect their intellectual property rights. Success in these areas will have a fundamental impact on the industry's level of success in the marketplace.

At the domestic level, the European automotive industry will need to face the challenge of ensuring that new technologies are able to compete with complementary solutions already available on the home market (i.e. existing ICEs and the respective infrastructure). On the global scale they will also need to compete with solutions developed by the much larger emerging markets who, by contrast, will already be enjoying the advantage of a 'green field' domestic market. It is clear that a more comprehensive and holistic approach to meeting these challenges will be required, which takes into account the views of

manufacturers, service providers, equipment and commodity suppliers, as well as accountants.

Such an approach will require the industry to redirect a significant portion of its research and innovation capacity towards establishing integrated production systems to address all of the required elements (Figure 6). This can only be justified if a sustainable return on investment from the entire production network can be ensured.

Thus, the systems approach to achieving global competitiveness considers the entire supply chain, from the demands of the consumer, end user and citizen to the basic commodities and raw materials used in the final process.

Recommendations

This SRA 2010 turns the grand societal challenges into real opportunities by proposing a range of integrated research and innovation priorities for the road transport system. The objectives of these proposals are to achieve, by 2030, 'a road transport system that is 50% more efficient' than today in terms of decarbonization, reliability and safety of road transport applications, as well as aiming to maintain, and expand, the global competitiveness of the European automotive industry.

The committed and timely implementation of this Agenda will take the European road transport system another major step forward towards achieving the ultimate goal of sustainability, and will consolidate the world leadership position of one of Europe's key economic sectors, by delivering:

- the world's most advanced electric and ICE propelled vehicles;
- the world's most advanced vehicle concepts, best adapted to their application;
- a road infrastructure network and associated management structure that is able to support the world's highest traffic intensities, as well as providing the highest levels of accessibility and reliability;
- logistical services that hold the highest operational levels of integration and collaboration throughout the entire chain;
- the world's most energy-efficient urban mobility solutions, which will simultaneously guarantee the highest degree of accessibility;
- the highest levels of decarbonization for road transport fuels, and the most efficient use of fossil and renewable resources;
- the world's lowest level of fatalities and severe injuries per distance travelled, and the highest level of security in freight transport; and
- the world's most flexible and effective production and supply network, which is able to cope with the concurrent challenges of generating ample vehicle concepts, adapting to changing volumes and competing effectively in the global markets.

These achievements will enhance economic growth and provide high quality employment in Europe, and hence, are of critical significance to European society. But they also represent a research and innovation challenge that has never before been encountered by the industry or services sector, as no other industry has been faced with the need for such a dramatic transition. In fact, the ambitious guiding objectives for 2030, as presented in this Agenda, imply such a significant step change that the road transport-related industry will need to redirect a significant portion of its research and innovation capacity towards establishing the integrated production and services systems that will be required to meet these objectives. Meeting such a challenge would provide the industry with a significant competitive advantage in the global market for the foreseeable future; however, it would only be effective if a sustainable return on investment from the resulting production and services network can be ensured (global balance trade-off). Furthermore, over the transitional period leading towards 2030, a considerable level of additional public investment will be required to guarantee success. ETRAC therefore recommends that the European Commission and the Member States, in their respective framework programmes, reserve a budget for road transport, that reflects the major significance of the sector to the economy and to society.

In addition to the need for adequate levels of investment, another vital key to success will clearly be that of an effective private-public partnership throughout the entire process, from research and innovation to development and commercial deployment. When embarking on the proposals in this SRA 2010, all members of the ETRAC technology platform will be involved, together with other sectors in the European economy, including power generation, rail and waterborne transport, manufacturing, etc. After adoption of the Agenda, the next stage will involve the development of plans for implementation, and much attention will be given at this stage to establishing the broad scope of partnerships and cooperation that will be required in the future.

Recommendations ►►►

The timely establishment of a supportive policy framework will be an important key to a successful transition. The European industry's competitive position in the global market will depend to a considerable extent on balanced and long-term policy measures which enable the introduction of new services and technologies to the market. ERTRAC believes that the early demand for these innovative technologies can be created through demand-side measures and public procurement schemes.

Other issues of importance with regard to such a policy framework will include: standardization and regulations (in particular, on weights and dimensions or to protect data security and privacy involved with the progressive introduction of ICT in the road transport systems, as well as intellectual properties rights); pan-European strategies for development of the road infrastructure; integration of mobility planning with land-use and environmental policies; energy and mineral sourcing requirements; and the development of Europe's human capital. In particular, the latter will require the development of an enhanced education and training system to prepare Europe's workforce with the skills and competences required for the necessary research and innovation, and the

subsequent development and marketing of the resulting technology and services. It is ERTRAC's recommendation that the utmost priority be given to the timely coordination of these policies at the European level.

The proposals in this Agenda for an integrated programme of research and innovation have been prioritized according to a clear vision for future road transport. They are based on a consistent systems approach to addressing the societal needs for decarbonization, reliability, safety and global competitiveness. Therefore, this Agenda has a systemic nature. Further steps to implement this Agenda would involve drafting specific roadmaps on issue-driven actions at the applications level. A recent example is the European roadmap for the electrification of road transport, prepared jointly by ERTRAC, EPoSS and SmartGrids and which is shortly to begin large-scale, real-world demonstration.

ERTRAC believes that issue-driven research and innovation should focus on the major road transport applications (i.e. urban mobility, long-distance freight transport, and transport interfaces—see Figure 7) and on the integrated management and organizational

Figure 7 The major road transport applications are a focus for issue-driven research and innovation relating to the use of the road transport system

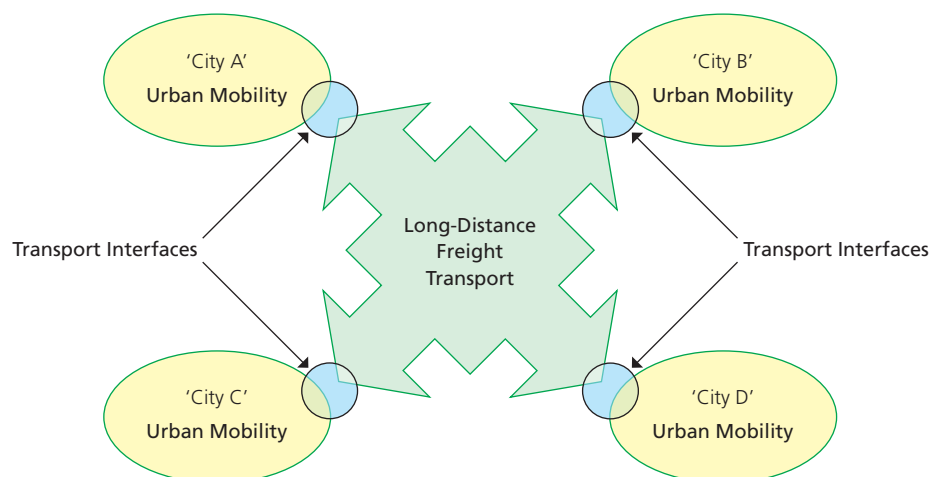
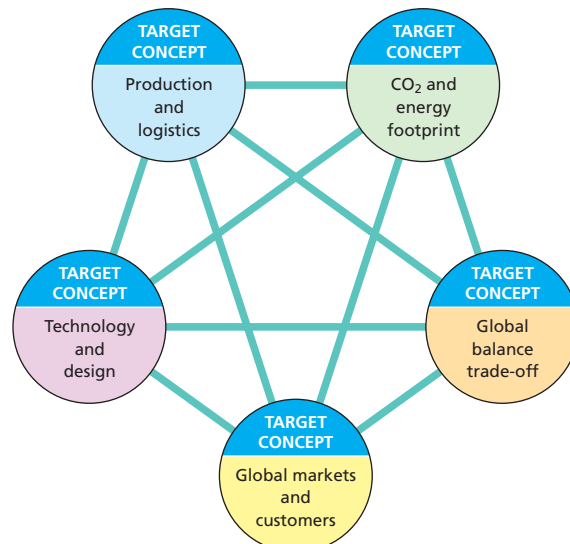

Figure 8 Key management and organizational aspects of production systems (i.e. target concepts) are a focus for issue-driven research and innovation relating to global competitiveness

Objectives

- To identify the challenges for relevant technologies, according to their economic, environmental or social impact
- To identify an integrated set of processes and technologies for each target concept (TC)
- To recognize that all target concepts within the system are complementary to each other, and that no single TC will offer a stand-alone solution
- To recognize that any real situation in the future would be likely to draw on the technologies defined in each of the TCs



issues in the automotive production system (see Figure 8). This will provide the required momentum in the short term, whilst in the longer term, the results will disseminate into the rest of the road transport system. Therefore, ERTRAC is proposing three process initiatives (described below), two of which would effectively address the societal need for decarbonization, reliability and safety with respect to these major road transport applications, and the third would address the societal need for global competitiveness of the European automotive industry.

The process initiative for an efficient and decarbonized urban mobility system would focus on urban accessibility management, seamless mobility services, the transport interfaces between modes and networks, and the provision of an optimal mix of services to meet the diverse needs of urban mobility consumers.

The process initiative on efficient door-to-door logistics would address 'last mile' deliveries into urban areas by optimizing the interface between the existing green transport corridors and the urban

areas, and would also address the co-modality issues relating to these transport interfaces by focusing on modular vehicle/freight carrier design, and business models to enable intensive cooperation between different organizations involved in the transportation of goods.

For the process initiative on the the social need for global competitiveness ERTRAC proposes to initiate a *Global Sustainable Production Platform* that would address an initial set of global production process requirements in a systematic approach.

Cooperation with the European Commission and with Member States will be critical for the success of all three initiatives. Therefore, ERTRAC invites both private and public partners to discuss, and further develop, these proposed initiatives.

References

- ETSC 2010: *Open Letter to Commissioner Kallas on Setting Ambitious EU Road Safety Targets for 2020*. ETSC. 15 February 2010.
- ERTRAC 2009a: *ERTRAC Road Transport Scenario 2030+ 'Road to Implementation'*. October 2009.
- ERTRAC 2009b: *European Roadmap: Electrification of Road Transport*. October 2009. ERTRAC, EPoSS, SmartGrids.
- EU 2010: *EUROPE 2020, A strategy for smart, sustainable and inclusive growth*. March 2010. European Commission, Brussels. (COM(2010) 2020).
- LUND 2009: *The Lund Declaration: Europe must focus on the Grand Challenges of our time*. July 2010.

Glossary

BRIC nations	Brazil, Russia, India, China	ICT	Information and communication technology
CNG	Compressed natural gas	LCA	Life-cycle analysis
DME	Di-methyl ether	LCC	Life-cycle costing
e-Freight	ICT application capable of following the movement of goods	LPG	Liquefied petroleum gas
EPoSS	European Technology Platform on Smart Systems Integration	MFR	Micro-factory retailing
ERTRAC	European Road Transport Research Advisory Council	PHEV	Plug-in hybrid electric vehicle
EBIT	Earnings before interest and taxes	RFID	Radio frequency identification
EMC	Electro-magnetic compatibility	SRA	Strategic Research Agenda
ERA	Environmental risks assessment	SmartGrids	European Technology Platform for the Electricity Networks of the Future
ERP	Enterprise resource planning	TCO	Total cost of ownership
ETSC	European Transport Safety Council	v2g	Vehicle-to-grid
EV	Electric vehicle	v2i	Vehicle-to-infrastructure
HDI	Human development index	v2v	Vehicle-to-vehicle
HMI	Human-machine interface	VRU	Vulnerable road user
HV	Hybrid vehicle	WMS	Warehouse management systems
ICE	Internal combustion engine		

Appendix

Research priorities for European road transport towards 2030

The Appendix to this document, which appears on the following pages, presents an overview of ERTRAC's research and innovation priorities for each of the major societal needs, i.e. decarbonization, reliability, safety and global competitiveness. Additional details on the applicable leading indicators are provided as a reference.

The research and innovation priorities for addressing society's needs with respect to the major applications for road transport (urban transport, long-distance transport, and the transport interfaces) are categorized into the following four research domains

1. Vehicles;
2. Infrastructure;
3. Logistical and mobility services; and
4. Energy and resources.

The research and innovation priorities for addressing society's needs with respect to global competitiveness are categorized according to the following three economic indicators:

1. Economic success;
2. Environmental awareness; and
3. Social responsibility.

The following road maps indicate the time it will take for the proposed research and innovation to reach the point where its feasibility will be demonstrated. It should be noted, however, that innovation and research, by nature, holds a degree of uncertainty that will increase with the time it takes to reach a decision on commercialization.

The projected deliveries are described in the right hand column of each road map. These deliveries will be prototypes, pilots, etc. that will demonstrate the feasibility of the proposed solutions. Typically, this research will continue towards the development of subsequent generations of the technologies concerned; these stages will be addressed in later SRAs.

RESEARCH AND INNOVATION PRIORITIES FOR DECARBONIZATION

The leading indicators for decarbonization of road transport are the energy-efficiency of urban passenger transport, the energy efficiency of long-distance freight transport and the share of renewables in the fuel pool combined with the volume of electric energy consumed in road transport.

By 2030 the energy efficiency of urban passenger transport will have increased by 80 per cent, and that of long-distance freight transport will have increased by 40 per cent, with respect to a 2010 baseline. The decarbonization of the energy basis for road transport is concerned with increasing the share of renewables in the fuel pool, and increasing the volume of electric energy made available to

road transport. Currently, biofuels constitute a 5 per cent share of the fuel pool. The guiding objective for 2030 is to replace 25 per cent of road transport fossil fuels with biofuels, which is in line with the vision of the European Biofuels Technology Platform. In addition, ERTRAC expects a 5 per cent substitution of road transport fuels with electricity, and the assumption is that this will be generated from renewable sources. In total, this would amount to a decarbonization of transport energy by approximately 20 per cent, as compared to a business-as-usual approach, which is additive to efficiency gains and other effects.

2010-2015
2015-2020
2020-2025
2025-2030+

RESEARCH DOMAIN

DELIVERABLES

Vehicles

- Integrated drivelines
- Energy management
- v2v and v2i communications and cooperative systems

The feasibility of the next generation of energy-efficient engine concepts will be demonstrated. These will be multi-fuel engines with advanced exhaust after-treatment and control systems designed to maximize the recovery of waste energy. In addition, the first generation of vehicle energy management systems will be demonstrated, which will have the capability to optimize the efficiency of the vehicle/journey based on a range of parameters including, e.g. the nature of the journey, choice of route, and traffic situation, etc. Large-scale testing of the first generation of robust, platform-independent v2v and v2i communications will be completed, marking a further milestone on the route towards cooperative systems. The benefits to decarbonization will be assessed.

- Electric vehicles
- Reduced resistance to motion
- Advanced driver support systems
- Matching vehicles to tasks

Medium-term research on electric vehicles will deliver new drive-train technologies (see also ERTRAC, 2009b). Large-scale testing will be carried out to assess the practical issues relating to the introduction of electric vehicles into the urban mobility system, e.g. with regard to the applicability to different modes, issues relating to parking and recharging, and user behaviour. This will provide an insight into the provisions and incentives that will be required for the effective integration of electric vehicles on a network scale. Additional research will investigate the potential for further gains in energy efficiency, e.g. by improving aerodynamics, reducing rolling resistance and vehicle weight, etc., as well as through advanced driver assistance/support systems designed to assist the driver in reducing fuel consumption. Finally, the first prototypes of a suite of new design concepts for freight transport vehicles will be presented which will use standardized load carriers designed for the flexible transportation of a variety of goods in a wide range of quantities across different transport modes, while minimizing the movement of dead weight and maximizing fuel efficiency. This is a first step in a continuing process of sophistication. The benefits to decarbonization will be assessed.

- Automated systems

A medium-term, full-scale demonstration of the automated transfer of goods will be carried out. In the longer term, a field operational test will be carried out, in a segregated area dedicated to pilot testing, to observe the practical issues relating to supervised autonomous driving (e.g. platooning, 'reserved lane' concepts, etc.) as a first step towards fully automated systems in the longer term. Special attention will be paid to the socio-economic and legal issues relating to the wide implementation of such systems. The benefits to decarbonization will be assessed.

Infrastructure

- Advanced road surface and bridge materials
- Efficient infrastructure maintenance and reconstruction
- Dynamic demand management
- Integrated mobility planning

Short-term research will focus on maximizing the availability and efficient management of the existing infrastructure capacity in order to reduce congestion. The durability and use of new material concepts, e.g. for use in roads, bridges, etc. will be demonstrated, and the costs/benefits will be assessed (together with their impact on GHG emissions) from a life-cycle perspective. A study will identify construction materials for which the production processes are less carbon-intensive than for concrete and steel. A further study will identify the maintenance and reconstruction technologies that will maximize the operational uptime of the integrated road transport network by reducing to a minimum the need for maintenance and repairs. Field trials on representative urban networks will demonstrate different types of dynamic and integrated traffic management schemes. These will include both physical (restriction) measures and fiscal access incentives such as charges, reimbursements and compensation. Studies on integrated mobility planning (e.g. optimized network management planning, including location and design of roads and interchanges for passenger and freight transport) will identify valid methods for optimizing mobility demand and reducing carbon emissions. In addition, these studies will address the benefits of novel techniques, including tunnelling, bridges and other structural concepts that will allow the cost-effective construction of roads that are flatter and possess fewer steep gradients. Methods to recover energy from the infrastructure will be developed, for use within the infrastructure, for neighbourhood use and for vehicles.

<ul style="list-style-type: none"> • Multi-modal infrastructure and interfaces • Integrated management of network infrastructure 			<p>Medium-term research will deliver models, validated by field tests, for the introduction of intelligent multi-modal interfaces and upgrades of the existing infrastructure, e.g. to accommodate the future electrification of road transport. Systems will be developed and tested in the field, that allow equitable sharing of the road space by the different modes and vehicles (people and freight) through new approaches to the design, construction, maintenance and management of the infrastructure. On a systems level, these and other elements will be integrated into a comprehensive and dynamic 'network infrastructure management system' designed to optimize usage of the (existing) road network, regardless of the time of day or weather conditions. This will make use of direct/real-time communications between the network operator and all road users (V2i communications and cooperative systems).</p>
<ul style="list-style-type: none"> • Dedicated infrastructure 			<p>Longer-term research will involve a series of field tests to examine the possibilities for dynamically adapting the infrastructure for a specific task, i.e. optimizing use of the infrastructure by targeting traffic separation and lane prioritization, and through the eventual introduction of electrified corridors for goods vehicles. This will include the 'green corridor' concept of dedicated transit routes that will contribute to decarbonization through the provision of high-quality infrastructure featuring, e.g. road surfaces with a low-rolling resistance, and routes with flatter profiles (i.e. fewer steep gradients) which would be achieved through the use of more efficient tunnelling and other structural techniques. The technologies available for on-road charging systems for powering electric vehicles will be assessed.</p>
Logistical and mobility services			
<ul style="list-style-type: none"> • Integrated information services • Understanding users mobility behaviour 			<p>A meta study will be delivered on the fundamentals that drive mobility demand (awareness, motivation, attitude and behaviour) and the potential for taking account of these data in the information services provided for use by the road transport user. The results of this study will be input into longer-term research into the possibilities for ultimately being able to predict and influence user behaviour and mobility patterns. This research on integrated information services will yield a study on the key parameters that would allow the secure and efficient exchange and sharing of information between actors in both the transport logistics and mobility services chains. The result will enable the development of comprehensive multimodal mobility information services for transport users, in which production systems management, e.g. enterprise resource planning (ERP), warehouse management systems (WMS), security systems, radio frequency identification (RFID), carbon sensitive planning and ICT for global trade compliance, are all included.</p>
<ul style="list-style-type: none"> • Integrated and optimized logistics services • Services at transport interfaces • Sustainable mobility services 			<p>Medium-term research will address the next steps in developing systems and business models to enable further collaboration between actors in the logistics and mobility chains, without compromising on competition (e.g. route planning regimes, open and platform-independent ITS solutions, and legal aspects related to the liability of the various actors). Related to this will be additional research on the integration of transport interfaces into the transport network, and on the specific services involved (e.g. architecture, alignment throughout Europe, national and regional application, ownership and access, and primary services such as parking and resting). Research on new mobility services in the urban environment will focus on new business models for high quality services that complement the current spectrum of urban mobility solutions (private car and public transport).</p>
Energy and resources			
<ul style="list-style-type: none"> • Energy storage and battery systems • Biofuels production • Advanced fuels production 			<p>In line with the European roadmap on electrification of road transport (see also ERTRAC, 2009b), high capacity batteries will be demonstrated, that are durable and require minimal recharging time. Research will address issues such as battery cell degradation and post-lithium cell technology, in addition to materials availability and waste management. Research on biofuels will yield (on a semi-industrial scale) demonstrations for next-generation production processes that can tap into a wider raw materials base. The focus will be on determining appropriate catalysts and process conditions, as well as the development of new and dedicated land and marine crops. Research on advanced fuels should demonstrate (on a semi-industrial scale) production technologies for fuels from conventional (fossil) sources adapted to vehicle requirements through further optimization of process technologies, e.g. including new catalysts, co-processing of fossil fuels and biomass, and carbon capture and storage for energy generation or DME production and properties optimization. This work will be intimately linked to research on the development of future powertrain systems, to achieve optimal performance on a well-to-wheels basis.</p>
<ul style="list-style-type: none"> • Closed loop recycling 			<p>Longer-term research will be concerned with new recycling concepts that will maximize the efficient use of materials within the road transport system itself, over the smallest loop possible. A prime area of focus will be vehicle electrification-related equipment such as batteries and conductors.</p>
<ul style="list-style-type: none"> • Grid-integration and reliability • High performance from abundant materials 			<p>Long-term research will target alternative materials from more abundant and less environmentally harmful resources, that will meet the required performance specifications and functions of the components used in the construction of future road vehicles. In particular, this research will target the development of lightweight composites, advanced alloys and non-precious metal catalysts. Technologies and practices will also be developed for achieving reliable EV-grid integration and advanced grid-traffic management solutions for optimal energy efficiency. This will focus on issues such as recharging technology (e.g. inductive charging, smart charging systems with online information and interoperability and bidirectional capabilities), recharging networks, protocols and devices for v2g communication, and business models for charging.</p>

RESEARCH AND INNOVATION PRIORITIES FOR RELIABILITY

The leading indicators for road network reliability are the reliability of transport schedules and urban accessibility. The objective is to achieve, by 2030, a 50 per cent increase in the reliability of transport schedules, acknowledging that a wide range of measures will be required in the face of increasing traffic intensity. In the context of urban mobility, the reliability of transport schedules is related to the important but complex issue of urban accessibility. Improvements in this indicator will require the optimization of the entire urban mobility system, with regard to economic and societal services and

functions, such as the extent to which jobs and services can be accessed, in terms of time, distance of travel, and possibly the cost of travel time lost. In view of the expected increase in mobility demand and the challenges of making changes to the urban landscape, ERTRAC's research ambitions aim to at least maintain the present levels of accessibility, and to improve them wherever possible. Although a number of definitions of these two indicators exist in principle, there is a need for a single, commonly accepted definition and method of measurement.

2010-2015
2015-2020
2020-2025
2025-2030+

RESEARCH DOMAIN

DELIVERABLES

Vehicles

- v2v and v2i communications and cooperative systems

A large-scale test of the first generation of robust, platform independent v2v and v2i communications will be completed, marking a further milestone on the route towards cooperative systems. The test will include an assessment of the effects on reliability improvement. The benefits to reliability will be assessed.

- Matching vehicles to tasks

The first prototypes of a suite of new vehicle design concepts will be presented, that can use standardized load carriers designed for the flexible transportation of a variety of goods in a wide range of quantities, across different transport modes while minimizing the movement of dead weight and maximizing fuel efficiency. The benefits to reliability will be assessed.

- Automated systems

A medium-term, full-scale demonstration of the automated transfer of goods will be carried out. In the longer term, a field operational test will be carried out, in a segregated area dedicated to pilot testing, to observe the practical issues relating to supervised autonomous driving (e.g. platooning, 'reserved lane' concepts, etc.) as a first step towards fully automated systems in the longer term. Special attention will be paid to the socio-economic and legal issues relating to the wide implementation of such systems. The benefits to reliability will be assessed.

Infrastructure

- Advanced road surface and bridge materials
- Efficient infrastructure maintenance and reconstruction
- Integrated mobility planning
- Assessment of (urban) accessibility
- Dynamic demand management

Short-term research will focus on maximizing the availability and efficient management of the existing infrastructure capacity in order to reduce congestion in all weather conditions. The durability and use of new material concepts, e.g. for use in roads, bridges, etc. will be demonstrated, and the costs/benefits will be assessed (together with an assessment of their reliability) from a life-cycle perspective. A further study will identify the maintenance and reconstruction technologies that will maximize the operational uptime of the integrated road transport network by reducing to a minimum the need for maintenance and repairs. Particular focus will be placed on winter and summer conditions as well as on extreme weather conditions. Studies on integrated mobility planning (e.g. optimized network management planning, including location and design of roads and interchanges for passenger and freight transport) will identify valid methods for optimizing mobility demand whilst maintaining network reliability. Furthermore, comprehensive decision support tools will be developed to enable public authorities to assess the possible impact of integrated policy packages on mobility (e.g. on location and opportunities for new transport infrastructure, including transport interfaces). In the same context, a European benchmark will be developed for assessing urban accessibility; this will provide a basis for a cost-benefit evaluation of possible measures to improve accessibility in specific urban settings. Finally results from current research on dynamic demand management strategies and schemes will be harvested (in relation to access restrictions and incentives such as charges, reimbursements and compensation).

- Multi-modal infrastructure and interfaces
- Integrated infrastructure network management

Medium-term research will deliver models, validated by field tests, for the introduction of intelligent multi-modal interfaces and upgrades of the existing infrastructure, e.g. to accommodate the future electrification of road transport. Systems will be developed and tested in the field, that allow equitable sharing of the road space by the different modes and vehicles (people and freight) through new approaches to the design, construction, maintenance and management of the infrastructure. On a systems level, these and other elements will be integrated into a comprehensive and dynamic 'network infrastructure management system' designed to optimize usage of the (existing) road network, regardless of the time of day or weather conditions. This will make use of direct/real time communications between the network operator and all road users (v2i communications and cooperative systems).

<ul style="list-style-type: none"> • Dedicated infrastructure 			<p>Longer-term research will involve a series of field tests to examine the possibilities for dynamically adapting the infrastructure for a specific task, i.e. optimizing use of the infrastructure by targeting traffic separation and lane prioritization, and through the eventual introduction of electrified corridors for goods vehicles. This will include the 'green corridor' concept of dedicated transit routes that will contribute to decarbonization through the provision of high-quality infrastructure featuring, e.g. road surfaces with a low-rolling resistance, and routes with flatter profiles (i.e. fewer steep gradients) which would be achieved through the use of more efficient tunnelling and other structural techniques. The technologies available for on-road charging systems for powering electric vehicles will be assessed.</p>
Logistical and mobility services			
<ul style="list-style-type: none"> • Integrated information services • Understanding users mobility behaviour 		<p>A meta study will be delivered on the fundamentals that drive mobility demand (awareness, motivation, attitude and behaviour) and the potential for taking account of these data in the information services provided for use by the road transport user. The results of this study will be input into longer-term research into the possibilities for ultimately being able to predict and influence user behaviour and mobility patterns. This research on integrated information services will yield a study on the key parameters that would allow the secure and efficient exchange and sharing of information between actors in both the transport logistics and mobility services chains. The result will enable the development of comprehensive multimodal mobility information services for transport users, in which production systems management (ERP/WMS), security systems, RFID, carbon sensitive planning and ICT for global trade compliance are all included.</p>	
<ul style="list-style-type: none"> • Integrated and optimized logistics services • Services at transport interfaces • Sustainable mobility services 		<p>Medium-term research will address the next steps in developing systems and business models to enable further collaboration between actors the logistics and mobility chains, with an emphasis on best practices. Related to this will be additional research on the integration of transport interfaces into the transport network, and on the specific services involved (e.g. architecture, alignment throughout Europe, national and regional application, and primary services such as parking and resting). Research on new mobility services in the urban environment will focus on new business models for high quality services that complement the current spectrum of urban mobility solutions (private car and public transport).</p>	
Energy and resources			
<ul style="list-style-type: none"> • Impact assessment and modelling 		<p>Short-term research will lead to the development of a coherent and sufficiently comprehensive methodology to assess and monitor the level of sustainability of existing and potentially promising production chains, from a well-to-wheels perspective. This will include an analysis of the impact of changes in fuel specifications on mobility, as well as a study of the economics related to the costs of future innovations.</p>	
<ul style="list-style-type: none"> • Fuel distribution and refuelling infrastructure • Energy storage and battery systems 		<p>Medium-term research will develop technologies and logistical networks to promote the introduction of advanced fuels and biofuels. This will address a variety of issues, e.g. the availability of charging and refuelling locations, hydrogen storage, multifuel handling equipment, protocols and specifications, supply chain design, logistics, standardization, fuel purity control, blending techniques and equipment, and high pressure fuel storage. It will also focus on the reliability of batteries and vehicle electrical systems, including standards and specifications, temperature, control systems to ensure safe charging, increasing number of charge/discharge cycles, and contactless charging.</p>	
<ul style="list-style-type: none"> • Grid-integration and reliability 		<p>Long-term research will focus on technologies and practices for achieving reliable integration between electric vehicles and the power supply grid, and also on integrated grid/traffic management solutions. In this regard, the issues to be addressed will include management and performance monitoring systems, standardization, modelling tools, charging protocols and equipment specifications.</p>	

RESEARCH AND INNOVATION PRIORITIES FOR SAFETY

The key indicators for safety and security in road transport are fatalities and severe injuries, and cargo lost to theft and damage. By 2030, fatalities and severe injuries in road transport will have been reduced by 60 per cent, relative to a 2010 baseline. This is consistent with the recommendations made by the European Transport Safety Council (ETSC) to Transport Commissioner Kallas (ETSC, 2010). It is worth noting that this objective is more comprehensive than any past objectives for safety, where

only fatalities were considered. One of the challenges of this guiding objective is that it is particularly concerned with reducing severe injuries.

By 2030, the value of cargo lost due to theft and damage will have been reduced by 70 per cent, based on the value transported, and relative to a 2010 baseline.

2010-2015
2020-2025
2025-2030*

RESEARCH DOMAIN

DELIVERABLES

Vehicles

- Safety of 'low carbon' vehicles
- Tyre-road surface interaction and friction-force estimation
- Kinematic and biomechanical models
- Safety of vulnerable road users
- Management of driver behaviour
- Accidentology

Recommendations will be presented by industry on solutions, methods and standards to maintain or even improve existing (vehicle) safety levels, e.g. where it concerns the crashworthiness of lightweight vehicle designs, the coexistence of (alternative) fuels and (high voltage) electric powertrains, the acoustic perception of electric vehicles and the subsequent standards for safety, electro-magnetic compatibility (EMC).

A pilot demonstration will be carried out to assess the capability for direct measurement of the tyre-road surface interaction in terms of friction and force applied, in combination with an assessment of related safety benefits. These will enable new solutions for improving vehicle dynamics and control in an emergency situation.

The first validated model for an impact assessment of passive safety in the vehicle will be presented. With the integration of primary and secondary safety systems, a greater understanding of impact on the human body will play an increasingly important role in the development and fine-tuning of such systems. Research will be necessary on advanced 'human' simulation models for all kinds of road users, and on improvement of the biofidelity and injury prediction capability of these advanced models, including, for example, the ability to simulate muscular activity.

Guidelines for the future development on the knowledge field. The protection of vulnerable road users (VRUs) has for a long time focused on mitigating the consequences of collisions between pedestrians and cars. A broader approach will be necessary, taking into account additional types of vulnerable road users and other types of vehicles, and all accident phases.

The first version of a tool for measuring and simulating driver behaviour will be presented. Guidelines for managing driver behaviour will be made available, in particular concerning safety and fuel consumption. These will provide information on the 'causal chain' that determines particular driver behaviour, such as to be able to ultimately predict and manage behaviour in real time, as well as over the longer term, given a limited set of parameters. Research will also focus on the continuous monitoring of the driver/vehicle/road condition and the application of best practice to the development of systems for on-board, real-time driver training/coaching.

Recommendations will be made for an EU-wide standard methodology to address road accidents, including the first version of an accident simulation tool. Research will be needed in the field of accidentology to obtain reliable and detailed information on the root causes of accidents in road transport. This will lead the way towards improvements in methods, tools and procedures to support the prevention of accidents and their negative consequences, and will guide the assessment of safety measures and concepts (e.g. naturalistic driving).

Short-term research will lead to successful large-scale testing of the first generation of robust, platform-independent v2v and v2i communications, marking a further milestone on the route towards cooperative systems. This will include business models for introducing the technology to the market (e.g. with respect to liability issues). The key to implementation will be a sound, technical and legal framework on a European, if not worldwide scale, through which data security and the protection of privacy will be guaranteed.

Research on advanced driver assistance/support will yield prototype systems to demonstrate the contribution to safety and efficiency to vehicle operation. Such technology will extend the level of driver support to include collision avoidance, as well as full autonomous driving on dedicated roads or in specific areas. The following prototypes and pilots are foreseen:

- v2v & v2i communications and cooperative systems
- Advanced driver assistance/support systems
- Safeguarding systems against theft and damage

<ul style="list-style-type: none"> • Driver-vehicle interface: real-time support for the driver by means of an ergonomically designed, and sociologically/physiologically justified human-machine interface (HMI) that provides the driver with optimum use of the (increasing level of) intelligence in the vehicle, without distracting the driver or compromising the driver's ability to remain in control of the vehicle. Proper management of the extended level of information available will contribute to improving driving behaviour, and lead to reduced fuel consumption and increased levels of safety. • Impaired driver monitoring: reliable yet non-intrusive on-board enforcement systems that detect/measure driver status, e.g. with regard to the influence of intoxicating substances (an analogy to the current alcohol-lock), distraction, drowsiness and illness, and which will consequently provide full support if the situation is deemed to become dangerous. • Intelligent driving dynamics: advanced systems for the control of vehicle dynamics, particularly during emergency manoeuvres (i.e. collision avoidance support), incorporating the latest technologies for, e.g. the dynamic detecting and interpretation of the immediate environment. <p>Field operational tests will be carried out to demonstrate integrated solutions for preventing the theft of freight, and the swift recovery of stolen freight by (law) enforcement. The challenge will be to provide sufficient data-security and privacy protection. In addition, systems will need to be developed that safeguard freight against damage during transport.</p>			
<ul style="list-style-type: none"> • Automated systems 			<p>Field operational test will be carried out, in a segregated area dedicated to pilot testing, to observe the practical issues relating to supervised autonomous driving (e.g. platooning, 'reserved lane' concepts, etc.) as a first step towards fully automated systems in the longer term. Special attention will be paid to the socio-economic and legal issues relating to the wide implementation of such systems. The benefits to reliability will be assessed.</p>
Infrastructure			
<ul style="list-style-type: none"> • Self-explaining and forgiving infrastructure 			<p>Industry and operators will be in agreement on common methodical standards for: assessing levels of road safety; the design of 'self-explaining' and 'forgiving' road concepts; and the road-side component of driver support systems. Emphasis will need to be placed on the interface between the infrastructure and the advanced on-board systems supporting the driver with reliable real-time information, e.g. on-road conditions, local weather conditions, traffic situations, etc. This will open the way for the further development of cost-effective solutions and best practice in the longer term, aimed at a comprehensive safety standard that will meet the targets set by European and national policies.</p>
<ul style="list-style-type: none"> • Secure road transport facilities 			<p>Several full-scale pilot schemes will demonstrate cost-effective measures concerning secure resting/parking areas for freight transport, and park-and-ride services for passenger transport. Research will need to cover intelligent and integrated monitoring (e.g. tracking and tracing) and surveillance concepts for both passengers and freight, and must acknowledge the requirement for data security and the protection of privacy.</p>
Logistical and mobility services			
			<p>There are no research and innovation priorities under the enabling perspectives for Logistical and mobility services.</p>
Energy and resources			
			<p>There are no research and innovation priorities under the enabling perspectives for Energy and resources.</p>

RESEARCH AND INNOVATION PRIORITIES FOR GLOBAL COMPETITIVENESS

The indicators for global competitiveness are selected especially to reflect the sustainability level of the entire road transport-related production system in terms of the economy, the environment and society. The indicators not only address the industry itself but also apply to the consumer market for road transport, and end users as well as residents, as it is their demands and wishes that drive supply

and provide industry with its return on investment. The indicators selected are: the total cost of ownership (TCO); earnings before interest and taxes (EBIT); the energy footprint of the supply chain; and the Human Development Index (HDI).

	2010-2015	2015-2020	2020-2025	2025-2030+	DELIVERABLES
RESEARCH DOMAIN					
Economic success					
Production processes					<p>Research will be needed on global supply to/from decentralized sites and mini production plants in the automotive industry, with respect to robustness of the process and site utilization, and in consideration of the respective sustainability constraints.</p> <p>Research will be required on programmes to enable the necessary product flexibility for the volatile automotive industry (in terms of total volume and product range) in the most economical way, whilst at the same time maximizing cash-flow efficiency for the less flexible parts of the industry.</p> <p>The development of criteria to determine the optimum site locations for international companies will be required; this will aim to achieve sustainable competitiveness, e.g. with regard to sourcing, production and sales (potentially enhanced towards engineering). Industry will need to be closer to its markets and able to respond to global market spread. The balance between the use of energy required, and the need to control emissions and pollution in global production processes and logistical systems will need to be examined, and crucial parameters will need to be established. In addition, it will be essential to address the development of regional industry partners.</p> <p>Research will be needed on ways to maximize manufacturing efficiency so that the widest range of products (e.g. traditional cars, HVs, PHEVs and EVs) can be produced simultaneously in the most economic manner. This will require maximum flexibility of the final assembly lines, and the development of standardized products and components that are common to the entire value chain. The need for small series production and varying series volumes need to be taken into account. Manufacturing execution systems (MES) and similar tools will need to be developed and implemented to enable rapid response times with minimum cost in the event of contingencies.</p>
Logistics processes					<p>Research will be needed on the design of 'one employee-one product' factories that can be set up quickly, and close to the market, enabling a move away from the central 'power-plant approach' in manufacturing towards a de-centralized 'windmill approach' yielding the next dimension of 'Lean Thinking'.</p> <p>Research will be needed on ways to enable the shift from ICs via PHEVs to EVs in automotive production and logistics; this will require the consideration of new 'players' including completely new production networks, together with a study of the different types of distribution networks, e.g. micro-factory retailing (MFR).</p> <p>Novel data, intelligence and ICT tools will need to be considered that will enable real-time connectivity between global production sites and the associated logistical systems; this will address new methods and support services for the acquisition/provision of knowledge management and for management of the social interaction.</p>

		<p>Research will be needed on ways to enhance the reliability of global market forecasts, and to provide methods for the real-time sharing of information between actors in the supply network, particularly at times of instability in global markets and the business economy. Measures will need to focus on accurate forecasting, consistent and accurate processing of information, and the ability of the supply grid to react to market changes in real time.</p> <p>Research will be needed on regulatory systems, with particular regard to technical standards and regulations for future EVs. The impact of electric vehicles on the growth in the market share of global companies will need to be evaluated, together with the effects on relationships between automotive producers and suppliers.</p>
Environmental awareness		
		<p>Research will be needed on methods for integrating environmental criteria into the design and development of products, services and processes in the context of global production; the development and implementation of Life Cycle Assessment (LCA) tools will be required to enable environmental impacts to be reduced across the entire lifecycle of a product. In addition methods will be required to measure and evaluate the sustainability of products, processes and materials, and industrial practices (e.g. LCA, Life Cycle Cost (LCC), Environmental Risks Assessment (ERA), etc.) in order to assess manufacturing sustainability within global networks.</p>
		<p>Techniques for simulating transport system dynamics will be required that will enable optimal planning and control of transport flows. The construction of simulation models and sub-models will be needed which can accommodate a range of criteria, including dense, free flowing and safe traffic inside any supply route and at different times of the day or night.</p> <p>Research will be needed on CO₂ emissions from production and associated logistical systems at the global scale, and on the relationship between emissions and productivity/profitability of the automotive companies and related supply network. An advanced decision support and management tool will be required that is specifically aimed at the highly complex automotive supply and production network, to help achieve the optimum balance between economic success and environmental impact.</p> <p>Research will be needed on the development of simulation models to evaluate the characteristics and novel behavioural patterns of enterprise networks that operate under 'product co-existence' regimes, to contribute to a better understanding of the relationships between competition, cooperation, responsibility and trust in today's economy.</p> <p>The need for high volume production of future EVs at affordable prices will call for research on the development of requisite commodity management, and a systematic approach to the lifecycle for strategic materials.</p>
Social responsibility		
		<p>An evaluation of the involvement of local research teams will be required to ensure the full and appropriate use of intellectual resources. To achieve the excellence required in the local development of automotive components and systems will require: assessment of available skills; assessment of the expertise available through research institutes; development of improved industry-academia collaboration; and the development of extended organizational concepts with a focus on common strategies for learning and training.</p> <p>Research on core labour standards will be required: poor labour standards and the associated low cost of the end product provide an illegitimate boost to competitiveness and may result in a 'race to the bottom' in labour standards, worldwide. If the violation of labour standards results from discrimination, employment, output, and competitiveness will shrink accordingly.</p> <p>Research will be required to study the need to engage the experience of experts in engineering from around the world, as a result of the increasing complexity of products, e.g. the growing co-existence of new and different propulsion systems.</p>
Business processes	<ul style="list-style-type: none"> ● Real-time reactivity on changes in the global business scenarios ● Technical standards for EVs and their impact on global market penetration 	
Production processes	<ul style="list-style-type: none"> ● Renewable energies and environmentally neutral materials in global automotive production and logistics 	
Logistics processes	<ul style="list-style-type: none"> ● Optimized transport flow, i.e. 'what is where at which point in time' 	
Business processes	<ul style="list-style-type: none"> ● Network simulation studies ● Assessment of the Eco2 balance optimum and implementation ● Global sourcing and commodity management for automotive components 	
Business processes	<ul style="list-style-type: none"> ● Collaborative distributed engineering ● 'COMPEDIA': The wiki for global competence rating of research establishments and academia in automotive matters ● Labour standards and their implications on the automotive industry for global competitiveness 	



Acknowledgements

Rapporteur: Ruud Smit (Rijkswaterstaat)

This Strategic Research Agenda was prepared by the following Working Groups:

Working Group	Leader
Urban Mobility	Sylvain Haon (Polis)
Long Distance Freight Transport	Helene Niklasson (Volvo) Ian Knight (TRL)
Energy & Environment	Kenneth Rose (CONCAWE) Frank Seyfried (Volkswagen)
Road Transport Safety & Security	Gianfranco Burzio (CRF) Lali Ghosh (Delphi)
Global Competitiveness	Jean-Luc di Paola-Galloni (Valeo) Gloria Pellischek (Continental)

The ERTRAC website provides an overview of all experts both within the ERTRAC community as well as beyond, that have contributed to this SRA draft. See: www.ertrac.org

Comments on this draft can be addressed to: info@ertrac.org



www.ertrac.org

